

COMPARATIVE ASSESSMENT BETWEEN A COUNTERFEITED AND A GENUINE POWER BJT

VIOREL MIRON-ALEXE¹

Manuscript received: 29.07.2020; Accepted paper: 26.08.2020;

Published online: 30.09.2020.

Abstract. *Counterfeited electronic components and devices raise multiple problems both for the electronics manufacturing industry and for the end-user as well. It is already a known fact that most of the Asian electronics market is flooding the world with cheap electronic components and devices, that have low-quality standards and that pose, sometimes, a threat to the end user's experience or health, when using them. In this article it is assessed, to some degree, the electrical and physical performances of both a genuine power BJT (Bipolar Junction Transistor) and a counterfeited one, in order to observe and compare the uses and the limits of their potential, and what conclusions should be drawn from this comparative experimentation.*

Keywords: *BJT; counterfeit; genuine; infrared temperature; load.*

1. INTRODUCTION

Nowadays, a lot of confusion is being generated regarding the electronic components authenticity and origin [1], especially on the local retail market where the real price of a counterfeited electronic component is masked by the added value, thus, sometimes reaching the price of an original one. This pricing politics represents an easy psychological trap even for the experienced consumers, as some components can be full-fledged copies of the original, with a high level of identification and execution details, but with doubtful build materials and performances. Still, in most of the cases [2], the fake components can reach absurdly low prices when bought from the popular online wholesalers, so this would be the first solid hint regarding the quality versus the price, of the products that consumers might be interested in purchasing. Fortunately, there are also genuine electronic component wholesalers on the market, although few, and with somewhat limited stocks, that sell this merchandise for the right price [3]. Although rare, there is a chance where the known large stocks wholesalers, mix the stocks from different manufacturers, that can contain both counterfeited, refurbished and cloned components [4]. Technically speaking, unlike the counterfeited components, the cloned and refurbished components may have the physical and electrical parameters comparable with the genuine components, so basically they are within the datasheet specifications or within the product's standards of the original ones. There is no secret either that due to the industrial espionage and lack of regulations and laws, which should have been enforced by the government, the Asian manufacturers rebranded an unknown amount of western origin electronic components, with their own ones.

Surely, brave steps have been made in the last several years by some Asian electronic components manufacturers, regarding the assertion on the electronics market, with their own

¹ Valahia University of Targoviste, Institute of Multidisciplinary Research for Science and Technology, Energy and Environment Research Department, 130004 Targoviste, Romania.
E-mail: viorel.alex@valahia.ro.

brands and standards, but again, to what degree is the past intellectual property taken into account, we have yet to find out. The fake electronic components industry is both problematic and complex, with multiple branches that affect domains such as cybersecurity, IT&C, economics, marketing, business, politics, technologies, industries, military and medical systems; all within a never-ending war for trade supremacy between the West and the East.

As the counterfeited components subject is a fairly vast one, the focus of the research is on a tiny but important segment of the electronics domain, regarding the BJT power transistors, or to be more specific, the well known and used, TIP35C. The TIP (Texas Instruments Power) BJT series was first introduced in 1960 by the Texas Instruments electronics manufacturer and continues to be used today as well, due to their simple and robust construction. Both TIP35 and TIP36 are complementary silicon transistors, the first being in NPN configuration, while the second being in PNP configuration. They are mainly used for general purpose amplifiers, audio amplifiers and for linear power supplies, so basically everything that needs power amplification.

2. EXPERIMENTAL METHODS

In order to assess the physical and the electrical characteristics of the original and the fake TIP35C power BJT, several non-destructive and destructive, experimental techniques, were applied on the components. The transistors had the same ST manufacturer (STMicroelectronics) logo engraved; the genuine one was bought from a reputable certified online electronics seller, while the counterfeited one was bought from a local electronics store, both with the same purchasing price.

2.1. PACKAGING DIMENSIONS AND VISUAL INSPECTION (NON-DESTRUCTIVE)

The first common sense information that can be obtained in a comparative study, is from the physical dimensions of the components, the external package layout and the laser engraved codes.

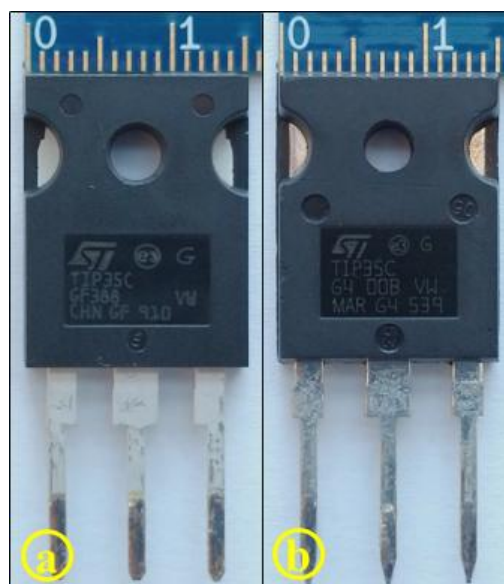

Figure 1. Front view: a-genuine transistor, b-counterfeited transistor.

As it can easily be acknowledged in Fig. 1, the laser engraved information on the two TO-247 transistor capsules were quite different, the same situation being with the physical sizes and the design layouts as well. According to the genuine transistor manufacturer's datasheet, the laser engravings contain information such as: device code, assembly location, manufacturing year, workweek and Pb-free package.

As expected, there were other design discrepancies between the two capsules regarding the edges and the dimensions of the pins as well, but without insisting on this matter, there is presented a back design comparison of the two capsules, in Fig. 2.

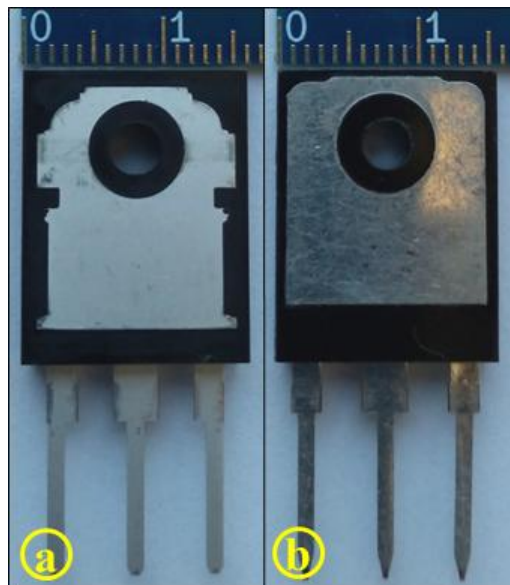

Figure 2. Back view: a-genuine transistor, b-counterfeited transistor.

The next step in the physical identification was represented by some typical calliper measurements of the packaging while comparing them with the original manufacturer's datasheet dimensions, which are found in Table 1.

Table 1. TO-247 comparative packaging dimensions (genuine manufacturer datasheet versus our two specimen measurements).

Data source	Length [mm]	Height [mm]	Width [mm]	Fixation hole ϕ [mm]
ST manufacturer's datasheet (min-max values)	15.45-15.75	19.85-20.15	4.85-5.15	3.55-3.65
Measured genuine BJT	15.59	20.10	5.00	4.06
Measured counterfeited BJT	15.36	19.92	4.72	3.33

To draw a small conclusion regarding the aspect and the size measurements of the two capsules - the fake component is slightly smaller, rougher and lacks the thermal conductive silver plating on the metallic case, compared to the original one.

It might be even possible that the alloy or composition of the metallic case can differ from one component to another, to further cut the manufacturing costs.

2.2. DIE DIMENSIONS AND VISUAL INSPECTION (DESTRUCTIVE)

Another way of gaining information about the manufacturing design of a silicon based component, is by splitting the capsule to visually inspect the silicon die. The two transistors were mechanically split with a bench vise, and although the fake component opposed less resistance to cracking, the original one was way more harder to open. There were also conducted microscopic measurements to the size of the die to get an approximate idea about the electrical capabilities of the transistors. In Fig. 3, it is presented a macro image with two magnification levels, of the fake TIP35C transistor die, with a surface area of 2.25 mm^2 .

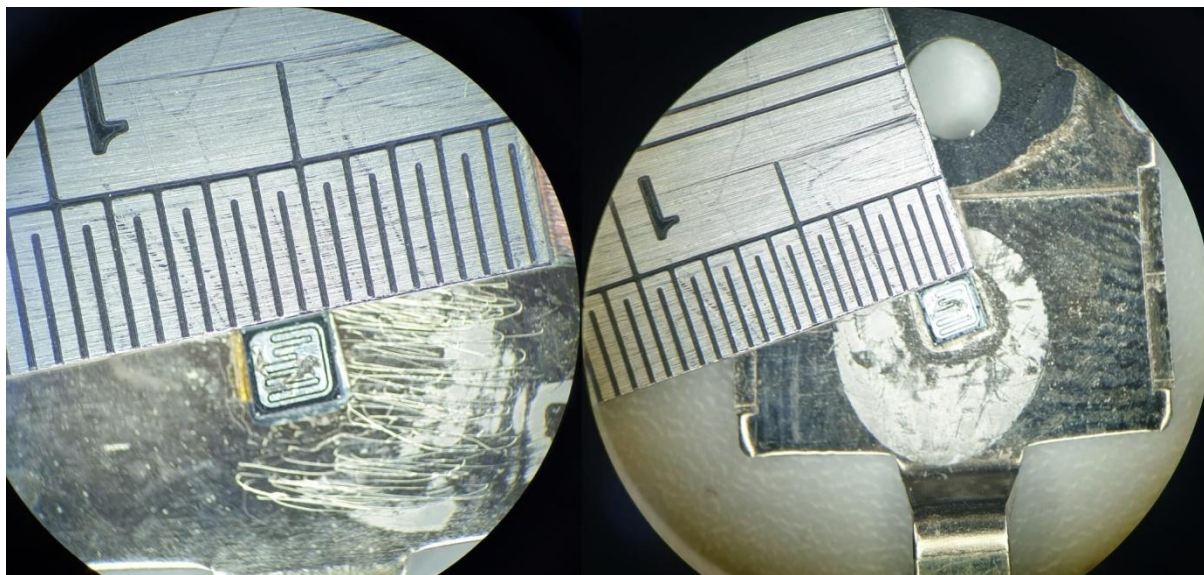

Figure 3. TIP35C counterfeited transistor, with two magnification levels of the die size measurement.

It was observed that the small silicon die was potted in a white silicone paste that had to be scraped off, in order to reveal it. It was impossible to measure the height of the die because of its thinness. In Fig. 4, it is also presented a macro image with two magnification levels, but of an original branded TIP35C transistor die, with a surface area of 14 mm^2 .

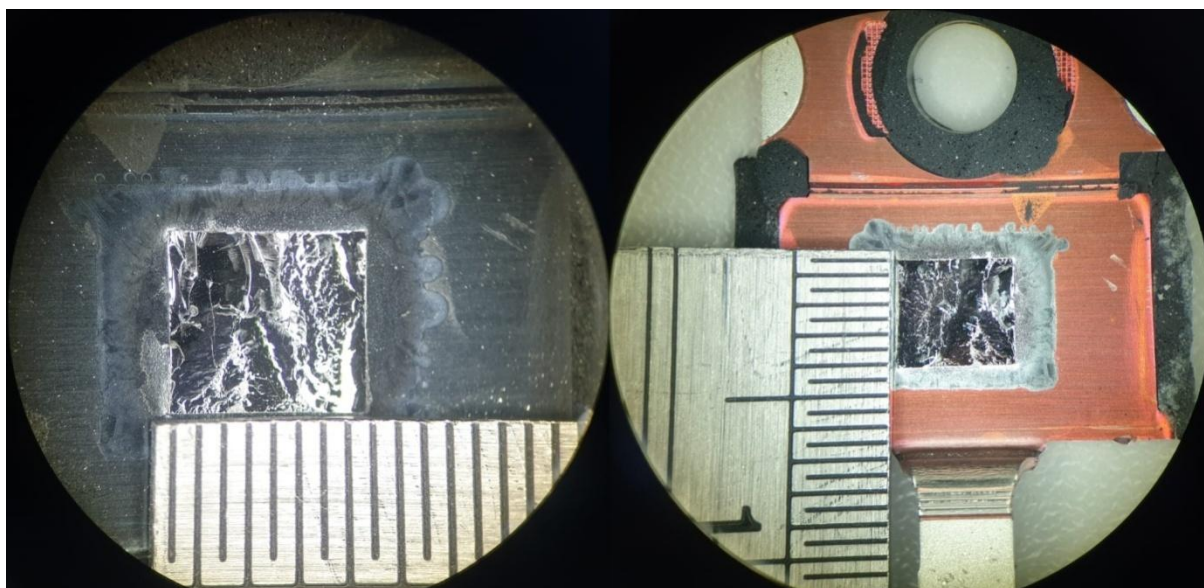

Figure 4. TIP35C genuine transistor, with two magnification levels of the die size measurement.

In this case, it was also impossible to measure the height of the silicone die, as upon cracking, the die fractured in two layers, one remaining on the metal plate while the other remained into the hard plastic capsule.

Fig. 5 represents a visual summary of the two dies, where the quality difference of the manufacturing materials are more than obvious.

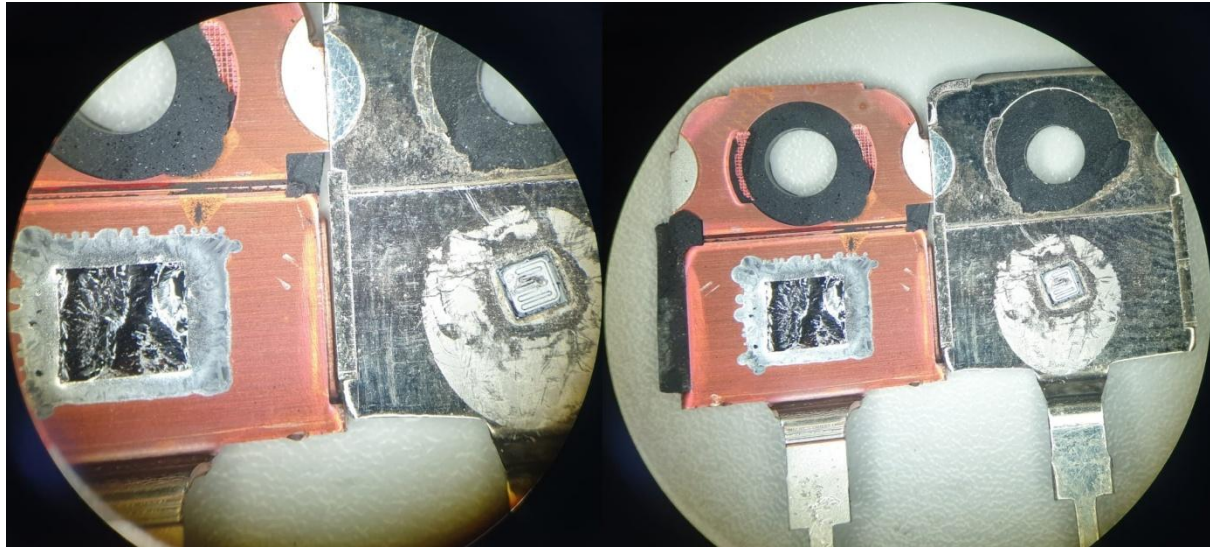

Figure 5. TIP35C genuine transistor die (left) versus counterfeit transistor die (right), with two magnification levels of the die size.

As a small conclusion, from the physical and electrical point of view, the fake transistor is nowhere near the original one, as a result, the thermal conduction and the capability of high currents conduction might be strongly off.

2.3. ELECTRONIC AND ELECTRICAL MEASUREMENTS

Another red flag, although not the most relevant to draw a decisive conclusion, whether a transistor can be fake or original, is when it is tested with a multimeter set up on „diode check” function. Usually, fake transistors have slightly different values from one component to another, while the genuine ones tend to have very close values between them.

Testing the BE pins (base-emitter junction) and the BC pins (base-collector junction) in forward-bias mode, of four transistor specimens (a pair of original manufacturer and another pair from an unknown manufacturer), unsurprisingly revealed the following results, which can be found in Table 2.

Table 2. Digital multimeter measurements of genuine and fake transistors BC/BE junctions (two pairs).

DMM measurements		
TIP35C	Junction voltage drop	
Sample	BC (forward bias) [V]	BE (forward bias) [V]
T1 – genuine BJT	0.615	0.616
T2 – genuine BJT	0.613	0.614
T3 – fake BJT	0.626	0.629
T4 – fake BJT	0.631	0.633

In theory, a higher voltage drop means a higher resistance, although the value differences between the two sets of specimens are marginal, this can indicate different composition of the transistor's p-type semiconductor material (i.e., purity level, doping).

To further evaluate the electrical limits of the transistors, a testing rig was proposed that involved: a resistive load, two DC power supplies, a potentiometer and an extruded aluminium heatsink with a silicon pad for thermal conduction and electric isolation of the transistor capsule. In Fig. 6, a simulation [5] of the testing rig is presented, that describes a schematic and connections of the components with the measurement instruments used.

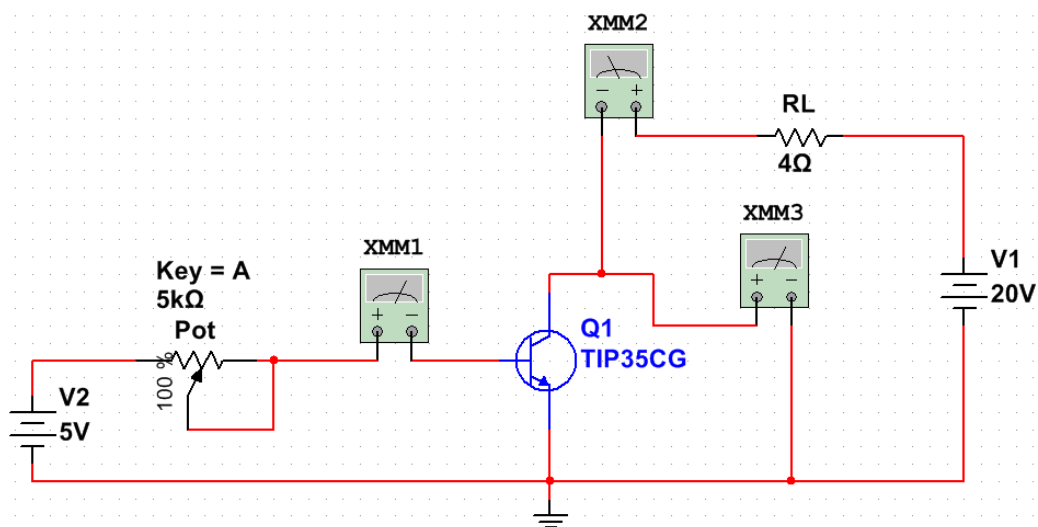

Figure 6. Multisim testing rig schematic with components, connections and multimeters.

In the simulated experimental rig, V_1 and V_2 are the DC power supplies, that work in CV mode (constant-voltage), with 5 V output for the transistor base and 20 V output for the RL represented by the load resistor of 4 Ω . The 5 k Ω potentiometer marked with A is used to adjust the current entering the transistor's base, and thus according to the β (h_{FE}) amplification factor of the transistor, it will allow a greater or a smaller CE (collector-emitter) current to flow through the RL [6].

The extruded aluminium heatsink parameters were not paramount, as it served as a support and as a temporary natural convection cooling buffer, for the transistor's operation within safe temperature specs, while making short IR thermal measurements.

The amperimeters are represented by $XMM1$ and $XMM2$, in order to indicate the initial current draw of the transistor's base and of the load, while the $XMM3$ voltmeter is used to indicate the voltage drop across the CE of the transistor under test.

In Table 3, the comparative data between the two transistors has been obtained through repeated experimentation with the testing rig.

The measured parameters were:

I_C – the collector current,

I_B – the base current,

V_{CE} – the collector-emitter voltage,

T – capsule surface temperature.

Table 3. Original versus fake TIP35C measurements (I_C , I_B , V_{CE} , T).

TIP35C	Original transistor			Fake transistor		
I_C [A]	I_B [mA]	V_{CE} [V]	T [°C]	I_B [mA]	V_{CE} [V]	T [°C]
0.5	9.58	17.94	44.2	0.50	17.95	49.9
1.0	18.30	15.73	62.4	12.00	15.78	71.6
1.5	26.46	13.60	75.7	22.04	13.71	86.9
2.0	34.35	11.54	85.8	36.45	11.56	98.1
2.5	42.42	9.49	92.0	55.32	9.51	104.3
3.0	52.21	7.21	93.2	84.80	7.23	103.2
3.5	61.70	5.16	88.4	123.30	5.35	97.0
4.0	72.90	3.14	78.4	185.30	3.66	89.4
4.5	94.50	1.11	62.0	487.00	1.19	68.8

The measurements were taken at 90 seconds apart one from another, at an ambient temperature of approximately 25-26°C.

2.4. INFRARED THERMOGRAPHY

The temperature measurements were conducted using a certified and calibrated infrared camera, to have a broader view on the heating zone of the capsules, while under the load. In Fig. 7, a set of ten IR thermal captures for the genuine BJT, are presented starting at the ambient temperature to the maximum given testing threshold.

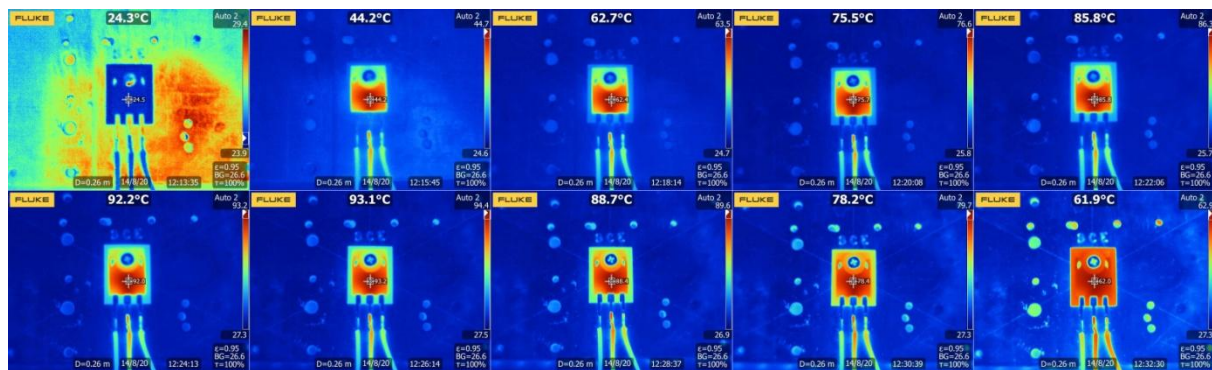

Figure 7. Thermal IR captures - genuine TIP35C mounted on the aluminium heatsink, tested with a resistive load.

In Fig. 8, a set of ten IR thermal captures for the counterfeited BJT, are as well presented starting at the ambient temperature to the maximum given testing threshold.

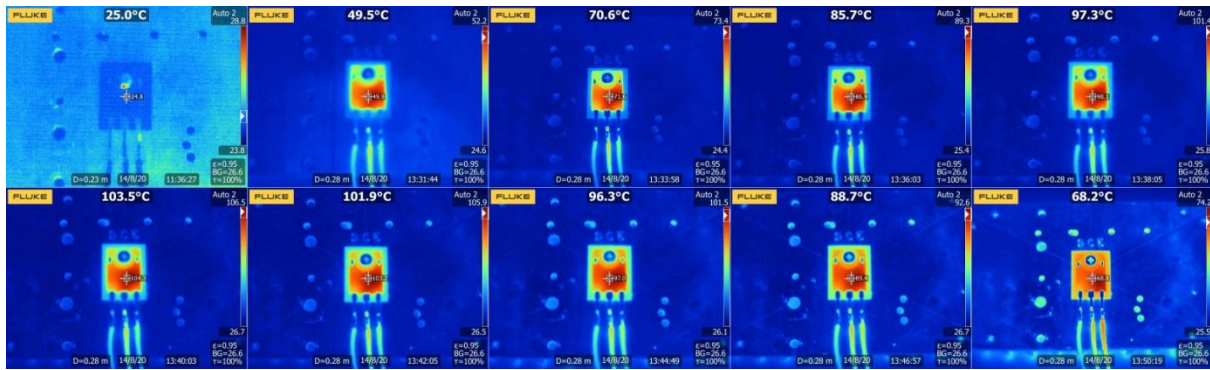

Figure 8. Thermal IR captures - counterfeit TIP35C mounted on the aluminium heatsink, tested with a resistive load.

3. RESULTS DISCUSSION

The procedure for the electrical measurement, was defined by increasing, in steps, the current value on the transistor base I_B , through the A potentiometer. As the base current increased, the transistor collector current I_C increased through the RL resistive load, while the voltage between the collector and the emitter V_{CE} dropped. Consequently, a rise in the transistor's temperature occurred according to the state of the transistor, being either in: cut-off mode, active mode or saturation mode.

The electrical measurements with a resistive load, backed up by the thermal IR ones, revealed different behaviours between the two transistors. Firstly, judging by the Table 3 results, the original transistor had a smoother temperature curve rise with a small peak between 2.5 A and 3 A, while the fake one had a more dramatic temperature rise and peak for the same load current.

Secondly, as both transistors slowly begun to enter saturation mode when $V_{CE} < 1.8$ V (according to datasheet), and when I_C current passed over 4.20 A, an unusual behaviour started to occur at the fake transistor, which began to draw a lot of base current. That was a strong proof that the fake transistor's capability to conduct a large current, has reached its maximum potential, thus it was somehow limited to about 4.5 A and started to fully saturate, while the maximum capability of the original transistor, was $I_C = 15$ A with $I_B = 1.5$ A and with a 50 A peak current ($t_p < 5$ ms), according to the manufacturer's datasheet.

Although not shown in the article for obvious reasons, the two transistors were also implemented and tested in a linear, CC/CV adjustable power supply, with a limiting capability of maximum 3 A and short circuit protection through the adjusted current limitation. In a repeated short circuit (maximum current limitation) scenario on the output of the power supply, the fake TIP35C transistor open-circuited, while the original one was working as expected. It seemed that the current draw shock, received by the fake transistor instantly destroyed it (Fig. 3. burned trace on the die).

There are four important relations to be calculated in order to find out if a transistor is in saturation mode.

In Fig. 9, there is presented a simple BJT model to further help with the calculations.

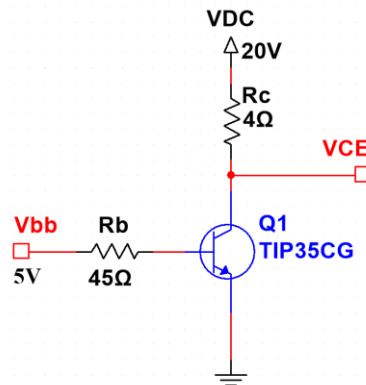

Figure 9. P-type BJT model.

If it is assumed that the transistor is in saturation mode, then the collector current I_C is affected by the R_C resistance. Thus results the (1) relation:

$$I_C = \frac{V_{DC}}{R_C} = \frac{20V}{4\Omega} = 5A \quad (1)$$

If the saturation voltage value $V_{CE(sat)}$, is included in the previous relation, it will result $I_{C(sat)}$ in relation (2):

$$I_{C(sat)} = \frac{V_{DC} - V_{CE(sat)}}{R_C} = \frac{20V - 1.8V}{4} = 4.55A \quad (2)$$

Knowing that the base voltage V_B is 5 V, and V_{BE} which is usually 0.7 V drop for silicone, then the base current I_B can be calculated with relation (3):

$$I_B = \frac{V_{BB} - V_{BE}}{R_B} = \frac{5V - 0.7V}{45\Omega} = 0.095A \quad (3)$$

Finally, to calculate the β of the transistor, the relation (4) is used:

$$\beta = \frac{I_C}{I_B} = \frac{5A}{0.095A} = 52.63 \quad (4)$$

4. CONCLUSIONS

The calculated β result value was very close to the maximum stated β (h_{FE})=50 in the datasheet, so it is highly possible that the original transistor was indeed just entering saturation mode at 4.5 A I_C and 94.95 mA I_B , while the fake transistor was just fully saturated at 4.5 A I_C and 487 mA I_B . There are indications that the fake transistor had different limits for all the three operating regions. As a general conclusion, and based on the research results, a genuine power BJT used in an electronic system will outperform a counterfeited one, and according to the expected specifications, if carefully exploited.

There were demonstrated in the experimentation, multiple ways to assess a counterfeited transistor, in order to promote responsible electronics consumption, by using only original or certified electronic parts.

REFERENCES

- [1] Pecht, M., *Open Journal of Social Sciences*, **1**, 12, 2013.
- [2] Stanciu, I., *Journal of Science and Arts*, **50**, 183, 2020.
- [3] Moldovan, M., Visa, I., Rusea, I. D., *Journal of Science and Arts*, **50**, 203, 2020.
- [4] Almaslamani, A., Constantin, M., Baran, N., Stoican, M. M., *Journal of Science and Arts*, **50**, 225, 2020.
- [5] Hasan, A., *Journal of Science and Arts*, **42**, 19, 2018.
- [6] Andrea Maria Nogueira Cavalcanti Ribeiro, Djamel Fawzi Hadj Sadok, Marcio Evaristo da Cruz Brito, Patricia Takako Endo, Judith Kelner, *IEEE Latin America Transactions*, **18**, 147, 2020.